

TRADE **UNI-D** MARK

SOLENOID VALVE

STEAM, AIR, WATER, OIL, GAS
VACUUM, HOT WATER, ETC.

— SCREWED END & FLANGED END —



QUICK REFERENCE CHART NORMALLY CLOSED & NORMALLY OPEN

The spot indicated on the effective area present the more the better, ●●● the best, ● ● better, good.

PHOTOGRAPH	MODEL	PIPE SIZE	OPERATING PRESSURE DIFF. KGf/CM ²	FLUID TEMP °C	STEAM	WATER	AIR	OIL	GAS	VACUUM
	UD	1/8" } 3/8"	0-7	-5°C } 80°C		● ● ●	● ● ●	● ●	● ●	● ●
	US	1/2" } 2"	0.5-15	-5°C } 185°C	● ● ●	● ●	● ●			
	US(F)	1 1/4" } 4"	0.5-10	-5°C } 185°C	● ● ●	● ●	● ●			
	UW	3/8" } 2"	0-7	-5°C } 80°C		● ● ●	● ●	● ●	● ●	● ●
	UW(F)	1 1/4" } 4"	0.2-8	-5°C } 80°C		● ● ●	● ●	● ●		
	UA	1/4" } 3/8"	0-9	-5°C } 80°C		● ●	● ●	● ●		
	UAO	1/4" } 1/2"	0.5-15	-5°C } 80°C		● ●	● ●	● ●		
	UDC	1/4" } 1/2"	0-1	-5°C } 120°C		● ●	● ●	● ●		
	SUS	1/2" } 1"	0.5-15	-5°C } 185°C	● ● ●	● ●	● ●	● ●		
	UAW	1/2" } 1"	2-15	-5°C } 80°C		● ● ●	● ●	● ●		
	UW(No)	3/8" } 1"	0.1-8	-5°C } 80°C		● ● ●	● ●	● ●		

- The details of each model, please refer to next each page.
- The standard voltage: AC 110V/220V (50/60Hz).
- Other voltage of AC/DC and normally open are available when required.

REMARK:

WIRE COLOR OF OUTLET COIL			
Voltage	AC110V	AC220V	OTHERS
Color	BLUE	RED	BLUE + RED

MODEL: UD-6,8,10, UD-6H,8H,10H NORMALLY CLOSED
FLUID : HOT WATER, WATER, AIR, OIL GAS & VACUUM.

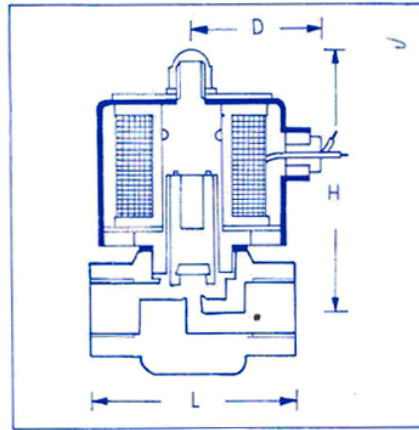

MATERIAL

PARTS NAME	MATERIAL
Body	Forge Brass
Coil	Special Copper Wire
Disc	NBR O Ring
Fixed Steel	Special St. Steel
Tube	Special St. Steel
Spring	St. St. 316

DIMENSION

mm

MODEL	UD-6	UD-8	UD-10	UD-6H	UD-8H	UD-10H		
L	41	41	53	41	41	53		
H	63	63	75	63	63	75		
D	21	21	48	21	21	48		
Weight/Kg	0.3	0.3	0.6	0.3	0.3	0.6		

SPECIFICATION and CHARACTER:

- 2-WAY normally closed solenoid valve.
- Type UD is normally closed, can direct operating without pressure, used for the fluid of Water, Air, Gas, Oil & Vacuum.
- The available operating pressure as follow:
 UD-6 and UD-8 : 0-7 Kg/cm²
 UD-10 : 0-10 Kg/cm².
 UD-6H and UD-8H: 0-20 Kg/cm².
 UD-10H : 0-20 Kg/cm².
- Standard voltage: AC 110V/220V (50/60 Hz.)
- Voltage is with $\pm 10\%$ differential.
- Small size & easy assembly.
- Other voltage of AC/DC available when required.
- Installation: Mountable in any position without affecting operation.

NOT FOR FLUID OF:

- Liquid when heat, solid when cool.
- Corrosive fluid.
- Viscosity over 50 cst.
- Temperature over 80°C of Centigrade: UD-6, UD-8 & UD-10
 Temperature over 130°C of Centigrade: UD-6H, UD-8H & UD-10H.

CAUTION:

- Pipes must be washed neat and clean before fitted
- A Y-STRAINER has to be installed in the front of solenoid valve, that is best for long life.

ANALYSIS

MODEL	CONNECTION PIPE SIZE	CV	ORIFICE MM	FLUID TEMP. °C	MAX. OPERATING PRESSURE DIFF. KGf/CM ²					
					HOT WATER	WATER	AIR	OIL	GAS	VACUUM
UD-6	1/8"	0.23	2.5	-5°C	0-7	0-7	0-7	0-7	0-7	0-10 ⁻⁶ Torr
UD-8	1/4"	0.23	2.5	}	0-7	0-7	0-7	0-7	0-7	0-10 ⁻⁶ Torr
UD-10	3/8"	0.60	4		80°C	0-10	0-10	0-10	0-10	0-10
UD-6H	1/8"	0.18	1.2	-5°C	0-20	0-20	0-20	0-20	0-20	0-10 ⁻⁶ Torr
UD-8H	1/4"	0.18	1.2	}	0-20	0-20	0-20	0-20	0-20	0-10 ⁻⁶ Torr
UD-10H	3/8"	0.45	2.0		130°C	0-20	0-20	0-20	0-20	0-20

NORMALLY OPEN AND UD-6H, 8H, 10H SPECIAL ORDER UD-8 ORIFICE 4mm, 6mm SPECIAL ORDER

MODEL: US-15,20,25,35,40,50 NORMALLY CLOSED
FLUID : STEAM, WATER & AIR

MATERIAL

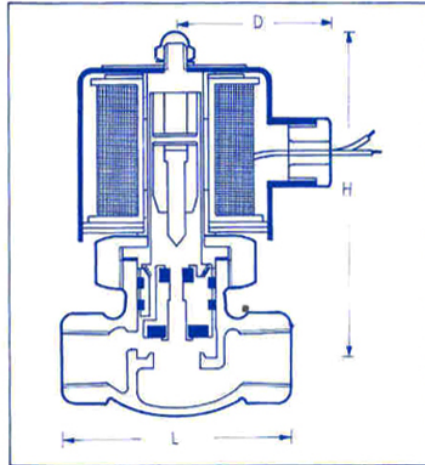

PARTS NAME	MATERIAL
Body	Brass/Bronze
Bonnt/Nut	Brass/Bronze
Coil	Special Copper Wire
Piston	Special Copper with PTFE O Ring
Main Valve	PTFE + 15% GF
Needle	Special St. Steel
Fixed Steel	Special St. Steel

DIMENSION

mm

MODEL	US-15	US-20	US-25	US-35	US-40	US-50		
L	82	82	91	110	111	163		
H	120	123	130	141	144	173		
D	58	58	58	58	58	58		
Weight/Kg	1.7	1.7	2.0	3.1	3.3	7.2		

SPECIFICATION and CHARACTER:

- 2-WAY normally closed solenoid valve.
- Type US withstand high temperature, best use for the fluid of STEAM, also for WATER & AIR.
- The available operating pressure: 0.5-15 Kg/cm²
- Standard voltage: AC 110V/220V (50/60 Hz.)
- Voltage is with $\pm 10\%$ differential.
- Simple construction & easy assembly.
- Other voltage of AC/DC available when required
- Installation: Mountable in level position only. (Prohibition in vertical position).

NOT FOR FLUID OF:

- Liquid when heat, solid when cool.
- Corrosive fluid.
- Viscosity over 20 cst.
- Temperature over 185°C of Centigrade.

CAUTION:

- Pipes must be washed neat and clean before fitted.
- A Y-STRAINER has to be installed in the front of solenoid valve, that is best for long life.

ANALYSIS

MODEL	CONNECTION PIPE SIZE	CV	ORIFICE MM	FLUID TEMP. °C	MAX. OPERATING PRESSURE DIFF. KGf/CM ²					
					STEAM	WATER	AIR	OIL	GAS	VACUUM
US-15	1/2"	4.0	17	-5°C 185°C	0.5-15	0.5-15	0.5-15	-	-	-
US-20	3/4"	6.0	17		0.5-15	0.5-15	0.5-15	-	-	-
US-25	1"	12	22		0.5-15	0.5-15	0.5-15	-	-	-
US-35	1 1/4"	18	30		0.5-15	0.5-15	0.5-15	-	-	-
US-40	1 1/2"	22	32		0.5-15	0.5-15	0.5-15	-	-	-
US-50	2"	48	50		0.5-15	0.5-15	0.5-15	-	-	-

NORMALLY OPEN SPECIAL ORDER

MODEL: US-35F, 40F, 50F, 65F, 80F, 100F NORMALLY CLOSED
FLUID : STEAM WATER & AIR

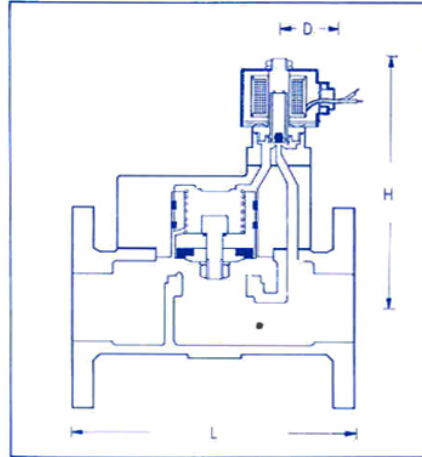

MATERIAL

PARTS NAME	MATERIAL
Body	FC25
Bonnt/Nut	FC25
Coil	Special Copper Wire
Piston	Special Copper with PTFE O Ring
Main Valve	PTFE + 15% GF
Needle	Special St. Steel
Fixed Steel	Special St. Steel

DIMENSION

mm

MODEL	US-35F	US-40F	US-50F	US-65F	US-80F	US-100F
L	200	200	210	240	300	340
H	224	226	246	278	295	325
D	58	58	58	58	58	58
Weight/Kg	10.5	10.7	13.5	17.8	24	33

SPECIFICATION and CHARACTER:

- 2-WAY normally closed solenoid valve.
- Type **USF** withstand high temperature, best use for the fluid of STEAM, also for WATER & AIR.
- The available operating pressure: 0.5-10 Kg/cm²
- Standard voltage: AC 110V/220V (50/60 Hz.)
- Voltage is with $\pm 10\%$ differential.
- Simple construction & easy assembly.
- Other voltage of AC/DC available when required.
- Installation: Mountable in level position only. (Prohibition in vertical position).

NOT FOR FLUID OF:

- Liquid when heat, solid when cool.
- Corrosive fluid.
- Viscosity over 20 cst.
- Temperature over 185°C of Centigrade.

CAUTION:

- Pipes must be washed neat and clean before fitted.
- A Y-STRAINER has to be installed in the front of solenoid valve, that is best for long life.

ANALYSIS

MODEL	CONNECTION PIPE SIZE	CV	ORIFICE MM	FLUID TEMP. °C	MAX. OPERATING PRESSURE DIFF. KGf/CM ²					
					STEAM	WATER	AIR	OIL	GAS	VACUUM
US-35F	1 1/4" (FIANGE)	22	35	-5°C	0.5-10	1-10	1-10	1-10	-	-
US-40F	1 1/2" (FIANGE)	30	40		0.5-10	1-10	1-10	1-10	-	-
US-50F	2" (FIANGE)	40	50	185°C	0.5-10	1-10	1-10	1-10	-	-
US-65F	2 1/2" (FIANGE)	68	65		0.5-10	1-10	1-10	1-10	-	-
US-80F	3" (FIANGE)	100	80		0.5-10	1-10	1-10	1-10	-	-
US-100F	4" (FIANGE)	175	100		0.5-10	1-10	1-10	1-10	-	-

FLANGE TYPE. 150PSI, 300PSI, SPECIAL ORDER

FLANGE TYPE US-15F PT 1/2", US-20F PT 3/4", US-25F PT 1" SPECIAL ORDER

MODEL: UW-10,15,20,25,35,40,50 NORMALLY CLOSED
FLUID : WATER, AIR, OIL, GAS & VACUUM.

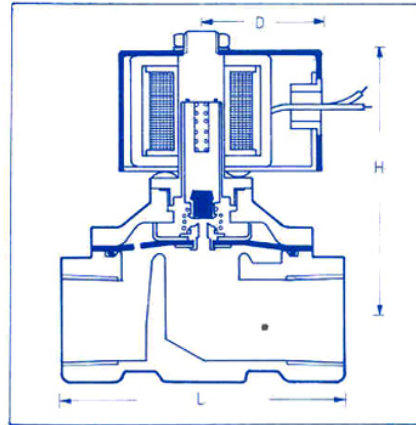
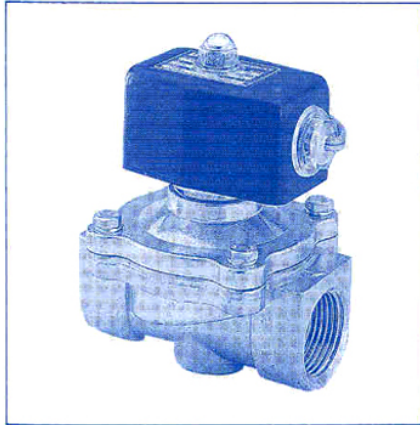

MATERIAL

PARTS NAME	MATERIAL
Body	Forge Brass
Bonnt/Nut	Forge Brass
Coil	Special Copper Wire
Diaphragm	N.B.R.
Disc	N.B.R.
Spring	St. St. 316
Fixed Steel	Special St. Steel

DIMENSION

mm

MODEL	UW-10	UW-15	UW-20	UW-25	UW-35	UW-40	UW-50
L	70	70	73	93	125	125	167
H	100	100	102	106	140	140	170
D	50	50	50	50	58	58	58
Weight/Kg	0.9	0.9	1.0	1.8	3.2	3.5	7.0

SPECIFICATION and CHARACTER:

- 2-WAY normally closed solenoid valve.
- Type UW is normally closed, can direct operation without pressure.
- For Fluid: Water, Air, Oil, Gas & Vacuum.
- The available operating pressure: 0-5 Kg/cm².
- Standard voltage: AC 110V/220V (50/60Hz).
- Voltage is with $\pm 10\%$ differential.
- Other voltage of AC/DC available when required.
- Small size, high flow, little electric power required.
- Installation: Mountable in any position without affecting operation.

NOT FOR FLUID OF:

- Liquid when heat, solid when cool.
- Corrosive fluid.
- Viscosity over 20 cst.
- Temperature over 80°C of Centigrade.

CAUTION:

- Pipes must be washed neat and clean before fitted.
- A Y-STRAINER has to be installed in the front of solenoid valve, that is best for long life.

ANALYSIS

MODEL	CONNECTION PIPE SIZE	CV	ORIFICE MM	FLUID TEMP. °C	MAX. OPERATING PRESSURE DIFF. KGf/CM ²					
					STEAM	WATER	AIR	OIL	GAS	VACUUM
UW-10	3/8"	2.4	10	-5°C 80°C	-	0-5	0-7	0-5	0-7	0-10 ⁻⁴ Torr
UW-15	1/2"	4.5	15		-	0-5	0-7	0-5	0-7	0-10 ⁻⁴ Torr
UW-20	3/4"	8.6	20		-	0-5	0-7	0-5	0-7	0-10 ⁻⁴ Torr
UW-25	1"	12	25		-	0-5	0-7	0-5	0-7	0-10 ⁻⁴ Torr
UW-35	1 1/2"	24	35		-	0-5	0-7	0-5	0-7	0-10 ⁻³ Torr
UW-40	1 1/4"	28	40		-	0-5	0-7	0-5	0-7	0-10 ⁻³ Torr
UW-50	2"	48	50		-	0-5	0-7	0-5	0-7	0-10 ⁻³ Torr

NORMALLY OPEN SPECIAL ORDER. AND USE FOR GAS SPECIAL ORDER.

MODEL: UW-35F, 40F, 50F, 65F, 80F, 100F NORMALLY CLOSED

FLUID : WATER, AIR, GAS & VACUM

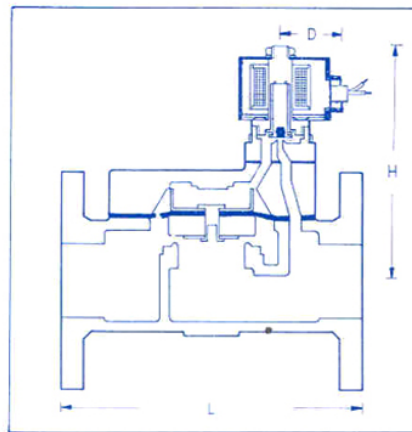

MATERIAL

PARTS NAME	MATERIAL
Body	FC25
Bonnt/Nut	FC25
Coil	Special Copper Wire
Diaphragm	N.B.R.
Disc	N.B.R.
Spring	St. St. 316
Fixed Steel	Special St. Steel

DIMENSION

mm

MODEL	UW-35F	UW-40F	UW-50F	UW-65F	UW-80F	UW-100F		
L	200	200	210	240	300	340		
H	224	226	246	278	295	325		
D	58	58	58	58	58	58		
Weight/Kg	8.8	9.4	11	15	20	30		

SPECIFICATION and CHARACTER:

1. 2-WAY normally closed solenoid valve.
2. Type UW is normally closed, can direct operation without pressure.
3. For Fluid: Water, Air, Oil, Gas & Vacuum.
4. The available operating pressure: 0.2-8 Kg/cm².
5. Standard voltage: AC 110V/220V (50/60Hz).
6. Voltage is with $\pm 10\%$ differential.
7. Other voltage of AC/DC available when required.
8. Small size, high flow, little electric power required.
9. Installation: Mountable in any position without affecting operation.

NOT FOR FLUID OF:

1. Liquid when heat, solid when cool.
2. Corrosive fluid.
3. Viscosity over 20 cst.
4. Temperature over 80°C of Centigrade.

CAUTION:

1. Pipes must be washed neat and clean before fitted.
2. A Y-STRAINER has to be installed in the front of solenoid valve, that is best for long life.

ANALYSIS

MODEL	CONNECTION PIPE SIZE	CV	ORIFICE MM	FLUID TEMP. °C	MAX. OPERATING PRESSURE DIFF. KGf/CM ²					
					STEAM	WATER	AIR	OIL	GAS	VACUUM
UW-35F	1 1/4" (FIANGE)	22	35	-5°C	—	0.2~8	0.2~8	0.2~5	—	—
UW-40F	1 1/2" (FIANGE)	30	40		—	0.2~8	0.2~8	0.2~5	—	—
UW-50F	2" (FIANGE)	40	50	80°C	—	0.2~8	0.2~8	0.2~5	—	—
UW-65F	2 1/2" (FIANGE)	68	65		—	0.2~8	0.2~8	0.2~5	—	—
UW-80F	3" (FIANGE)	102	80		—	0.2~8	0.2~8	0.2~5	—	—
UW-100F	4" (FIANGE)	180	100		—	0.2~8	0.2~8	0.2~5	—	—

FLANGE TYPE 150PSI, 300PSI SPECIAL ORDER

FLANGE TYPE: UW ~ 15F PT 1/2", UW ~ 20F PT 3/4". UW-25F PT 1" SPECIAL ORDER

MODEL: UA-8, 10 NORMALLY CLOSED

FLUID : AIR WATER & OIL

MATERIAL

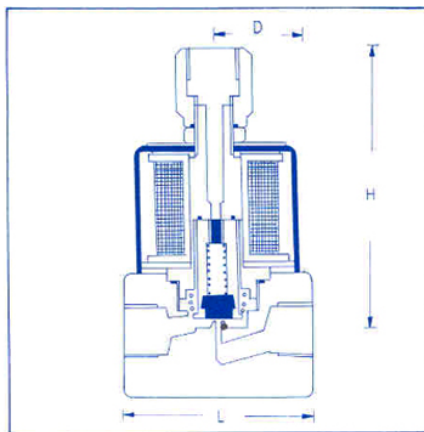

PARTS NAME	MATERIAL
Body	Forge Brass
Coil	Special Copper Wire
Disc	NBR O Ring
Fixed Steel	Special St. Steel
Tube	Special St. Steel
Spring	St. St. 316

DIMENSION

mm

MODEL	UA-8	UA-10						
L	33	34						
H	101	110						
D	21	48						
Weight/Kg	0.4	0.7						

SPECIFICATION and CHARACTER:

- 3-WAY normally closed solenoid valve.
- Type UA is normally closed, can direct operation without pressure.
- For Fluid: Water, Air, Oil, Gas & Vacuum.
- The available operating pressure: 0-10Kg/cm².
- Standard voltage: AC 110V/220V (50/60Hz).
- Voltage is with ± 10% differential.
- Other voltage of AC/DC available when required.
- Small size, high flow, little electric power required.
- Installation: Mountable in any position without affecting operation.

NOT FOR FLUID OF:

- Liquid when heat, solid when cool.
- Corrosive fluid.
- Viscosity over 20 cst.
- Temperature over 80°C of Centigrade.

CAUTION:

- Pipes must be washed neat and clean before fitted.
- A Y-STRAINER has to be installed in the front of solenoid valve, that is best for long life.

ANALYSIS

MODEL	CONNECTION PIPE SIZE	CV	ORIFICE MM	FLUID TEMP. °C	MAX. OPERATING PRESSURE DIFF. KGf/CM ²					
					STEAM	WATER	AIR	OIL	GAS	VACUUM
UA-8	1/4"	0.1	1.2	-5°C	—	0-10	0-10	0-10	—	—
UA-10	3/8"	0.12	1.5	80°C	—	0-10	0-10	0-10	—	—

NORMALLY OPEN SPECIAL ORDER. AND USE FOR GAS SPECIAL ORDER.

MODEL: UAO-8, 10, 15 NORMALLY CLOSED

FLUID : OIL , AIR & WATER

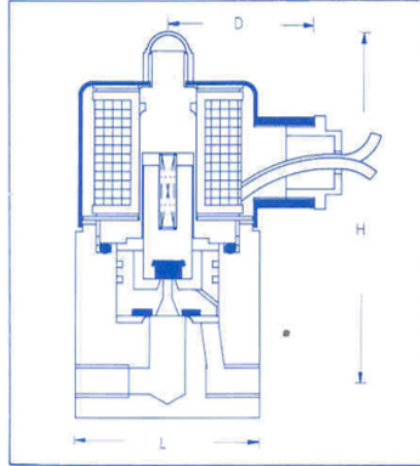

MATERIAL

PARTS NAME	MATERIAL
Body	Brass/Bronze
Bonnt/Nut	Brass/Bronze
Coil	Special Copper Wire
Piston	Special Copper with N.B.R. O Ring
Main Valve	NBR
Needle	Special St. Steel
Fixed Steel	Special St. Steel

DIMENSION

mm

MODEL	UAO-8	UAO-10	UAO-15				
L	49	49	49				
H	110	110	110				
D	48	48	48				
Weight/Kg	1.1	1.1	1.1				

SPECIFICATION and CHARACTER:

1. 2-WAY normally closed solenoid valve.
2. Type UAO withstand high temperature, best use for the fluid of OIL, also for WATER & AIR.
3. The available operating pressure: 0.5- 15 Kg/cm²
4. Standard voltage: AC 110V/220V (50/60 Hz.)
5. Voltage is with $\pm 10\%$ differential.
6. Simple construction & easy assembly.
7. Other voltage of AC/DC available when required.
8. Installation: Mountable in level position only. (Prohibition in vertical position).

NOT FOR FLUID OF:

1. Liquid when heat, solid when cool.
2. Corrosive fluid.
3. Viscosity over 20 cst.
4. Temperature over 80°C of Centigrade.

CAUTION:

1. Pipes must be washed neat and clean before fitted.
2. A Y-STRAINER has to be installed in the front of solenoid valve, that is best for long life.

ANALYSIS

MODEL	CONNECTION PIPE SIZE	CV	ORIFICE MM	FLUID TEMP. °C	MAX. OPERATING PRESSURE DIFF. KGf/CM ²					
					STEAM	WATER	AIR	OIL	GAS	VACUUM
UAO-8	1/4"	2.5	10	-5°C	—	0.5-15	0.5-15	0.5-15	—	—
UAO-10	3/8"	2.5	10	}	—	0.5-15	0.5-15	0.5-15	—	—
UAO-15	1/2"	2.5	10		80°C	—	0.5-15	0.5-15	0.5-15	—

NORMALLY OPEN AND SPECIAL ORDER

MODEL: UDC-8, 10, 15, NORMALLY CLOSED
FLUID : HYDROCHLORIC ACID, SULFURIC ACID

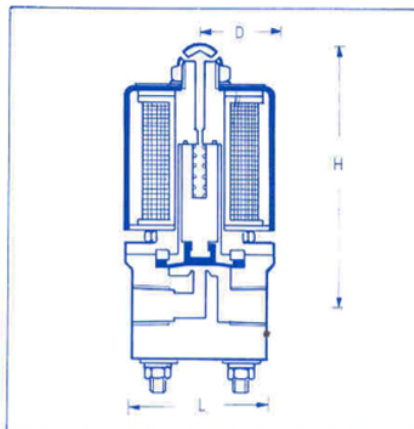

MATERIAL

PARTS NAME	MATERIAL
Body	Forge PVC
Bonnt/Nut	Forge St. St 316
Coil	Special Copper Wire
Diaphragm	PTFE
Disc	PTFE
Spring	St. St. 316
Fixed Steel	Special St. Steel

DIMENSION

mm

MODEL	UDC-8	UDC-10	UDC-15				
L	54	54	54				
H	120	120	120				
D	48	48	48				
Weight/Kg	0.6	0.6	0.6				

SPECIFICATION and CHARACTER:

- 2-WAY normally closed solenoid valve.
- Type UDC is normally closed, can direct operation without pressure.
- For Fluid: Hydrochloric Acid, Sulfuric Acid
- The available operating pressure: 0-1 Kg/cm².
- Standard voltage: AC 110V/220V (50/60Hz).
- Voltage is with ± 10% differential.
- Other voltage of AC/DC available when required.
- Small size, high flow, little electric power required.
- Installation: Mountable in any position without affecting operation.

NOT FOR FLUID OF:

- Liquid when heat, solid when cool.
- Corrosive fluid.
- Viscosity over 20 cst.
- Temperature over 80°C of Centigrade.

CAUTION:

- Pipes must be washed neat and clean before fitted.
- A Y-STRAINER has to be installed in the front of solenoid valve, that is best for long life.

ANALYSIS

MODEL	CONNECTION PIPE SIZE	CV	ORIFICE MM	FLUID TEMP. °C	MAX. OPERATING PRESSURE DIFF. KGf/CM ²					
					STEAM	WATER	AIR	OIL	GAS	VACUUM
UDC-8	1/4"	0.28	6.5	-5°C	—	0-1	0-1	0-1	—	—
UDC-10	3/8"	0.28	6.5	/	—	0-1	0-1	0-1	—	—
UDC-15	1/2"	0.28	6.5	80°C	—	0-1	0-1	0-1	—	—

MODEL: SUS-15, 20, 25 NORMALLY CLOSED

FLUID : HYDROCHLORIC ACID, STEAM, WATER & AIR

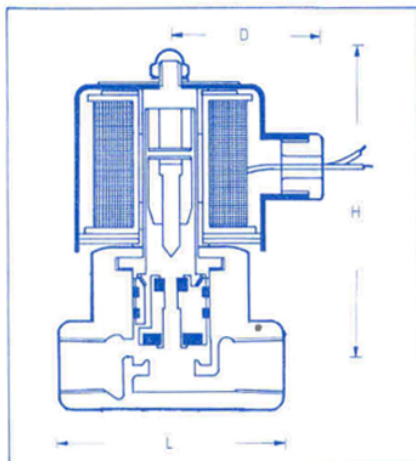

MATERIAL

PARTS NAME	MATERIAL
Body	SUS304/SUS316
Bonnt/Nut	SUS304/SUS316
Coil	Special Copper Wire
Piston	Special Copper with PTEF O Ring
Main Valve	PTFE
Needle	Special St. Steel
Fixed Steel	Special St. Steel

DIMENSION

mm

MODEL	SUS-15	SUS-20	SUS-25				
L	83	83	92				
H	157	157	184				
D	58	58	58				
Weight/Kg	2.6	2.5	3.5				

SPECIFICATION and CHARACTER:

- 2-WAY normally closed solenoid valve.
- Type **SUS** is best for the high pressure of fluid: Water & Air.
- The available operating pressure: 0.5 – 15 Kg/cm².
- Standard voltage: AC 110V/220V (50/60 Hz.)
- Voltage is with $\pm 10\%$ differential.
- Other voltage of AC/DC available when required.
- Simple construction & easy assembly.
- Installation: Mountable in LEVEL position only. (Prohibition in vertical position).

NOT FOR FLUID OF:

- Liquid when heat, solid when cool.
- Corrosive fluid.
- Viscosity over 20 est.
- Temperature over 185°C of Centigrade.

CAUTION:

- Pipes must be washed neat and clean before fitted.
- A Y-STRAINER has to be installed in the front of solenoid valve, that is best for long life.

ANALYSIS

MODEL	CONNECTION PIPE SIZE	CV	ORIFICE MM	FLUID TEMP. °C	MAX. OPERATING PRESSURE DIFF. KGf/CM ²					
					STEAM	WATER	AIR	OIL	GAS	VACUUM
SUS-15	1/2"	8.6	15	-5°C	0.5-15	0.5-15	0.5-15	—	—	—
SUS-20	3/4"	9.6	20	185°C	0.5-15	0.5-15	0.5-15	—	—	—
SUS-25	1"	12	25		0.5-15	0.5-15	0.5-15	—	—	—

MODEL: UAW-15,20,25,35,40,50 NORMALLY CLOSED

FLUID : WATER & AIR

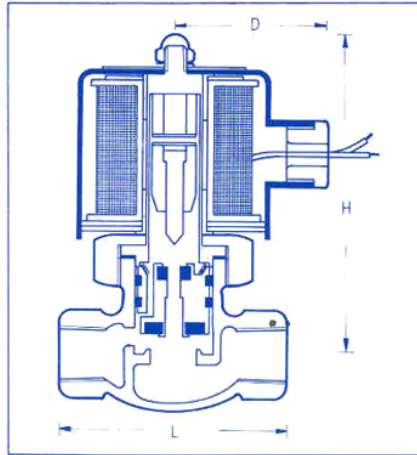

MATERIAL

PARTS NAME	MATERIAL
Body	Brass/Bronze
Bonnt/Nut	Brass/Bronze
Coil	Special Copper Wire
Piston	Special Copper with PTFE O Ring
Main Valve	N.B.R.
Needle	Special St. Steel
Fixed Steel	Special St. Steel

DIMENSION

mm

MODEL	UAW-15	UAW-20	UAW-25	UAW-35	UAW-40	UAW-50		
L	82	82	91	110	110	163		
H	120	123	130	141	144	173		
D	58	58	58	58	58	58		
Weight/Kg	1.7	1.7	2.0	3.1	3.3	7.2		

SPECIFICATION and CHARACTER:

- 2-WAY normally closed solenoid valve.
- Type UAW is best for the high pressure of fluid: Water & Air.
- The available operating pressure: 2 - 15 Kg/cm².
- Standard voltage: AC 110V/220V (50/60 Hz.)
- Voltage is with ± 10% differential.
- Other voltage of AC/DC available when required.
- Simple construction & easy assembly.
- Installation: Mountable in LEVEL position only. (Prohibition in vertical position).

NOT FOR FLUID OF:

- Liquid when heat, solid when cool.
- Corrosive fluid.
- Viscosity over 20 cst.
- Temperature over 80°C of Centigrade.

CAUTION:

- Pipes must be washed neat and clean before fitted.
- A Y-STRAINER has to be installed in the front of solenoid valve, that is best for long life.

ANALYSIS

MODEL	CONNECTION PIPE SIZE	CV	ORIFICE MM	FLUID TEMP. °C	MAX. OPERATING PRESSURE DIFF KGf/CM ²					
					STEAM	WATER	AIR	OIL	GAS	VACUUM
UAW-15	1/2"	4.0	17	-5°C 80°C	—	2-15	2-15	—	—	—
UAW-20	3/4"	6.0	17		—	2-15	2-15	—	—	—
UAW-25	1"	12	22		—	2-15	2-15	—	—	—
UAW-35	1 1/4"	18	30		—	2-15	2-15	—	—	—
UAW-40	1 1/2"	22	32		—	2-15	2-15	—	—	—
UAW-50	2"	48	50		—	2-15	2-15	—	—	—

NORMALLY OPEN SPECIAL ORDER

MODEL: UW-10NO, 15NO, 20NO, 25NO NORMALLY OPEN

FLUID : WATER, AIR, OIL

MATERIAL

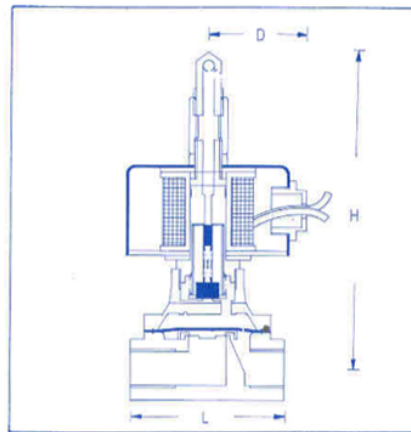

PARTS NAME	MATERIAL
Body	Forge Brass
Bonnt/Nut	Forge Brass
Coil	Special Copper Wire
Diaphragm	N.B.R.
Disc	N.B.R.
Spring	St. St. 316
Fixed Steel	Special St. Steel

DIMENSION

mm

MODEL	UW-10 NO	UW-15 NO	UW-20 NO	UW-25 NO
L	70	70	73	93
H	147	147	149	153
D	50	50	50	50
Weight/Kg	1.1	1.1	1.2	2.0

SPECIFICATION and CHARACTER:

- 2-WAY normally open solenoid valve.
- Type UWNO is normally closed, can direct operation without *pressure.
- For Fluid: Water, Air, Oil, Gas & Vacuum.
- The available operating pressure: 0.1-8 Kg/cm².
Standard voltage: AC 110V/220V (50/60Hz).
- Voltage is with $\pm 10\%$ differential.
- Other voltage of AC/DC available when required.
- Small size, high flow, little electric power required.
- Installation: Mountable in any position without affecting operation.

NOT FOR FLUID OF:

- Liquid when heat, solid when cool.
- Corrosive fluid.
- Viscosity over 20 cst.
- Temperature over 80°C of Centigrade.

CAUTION:

- Pipes must be washed neat and clean before fitted.
- A Y-STRAINER has to be installed in the front of solenoid valve, that is best for long life.

ANALYSIS

MODEL	CONNECTION PIPE SIZE	CV	ORIFICE MM	FLUID TEMP. °C	MAX. OPERATING PRESSURE DIFF. KGf/CM ²					
					STEAM	WATER	AIR	OIL	GAS	VACUUM
UW-10-NO	3/8"	2.4	10	-5°C 80°C	—	0.1-8	0.1-8	0.1-5	0.1-8	0.1-10 ⁻³ Torr
UW-15-NO	1/2"	4.5	15		—	0.1-8	0.1-8	0.1-5	0.1-8	0.1-10 ⁻³ Torr
UW-20-NO	3/4"	8.6	20		—	0.1-8	0.1-8	0.1-5	0.1-8	0.1-10 ⁻³ Torr
UW-25-NO	1"	12	25		—	0.1-8	0.1-8	0.1-5	0.1-8	0.1-10 ⁻³ Torr

FLOW CHARACTERISTIC CHART

STEAM/AIR P_1 = INLET PRESS KG/CM²
 STEAM/AIR P_2 = OUTLET PRESS KG/CM²
 WATER: DIFF. PRESS KGf/CM²

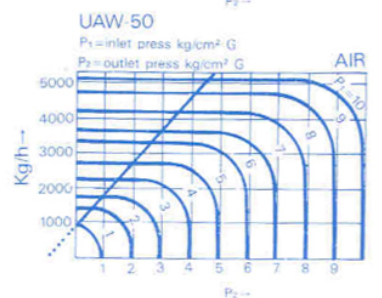
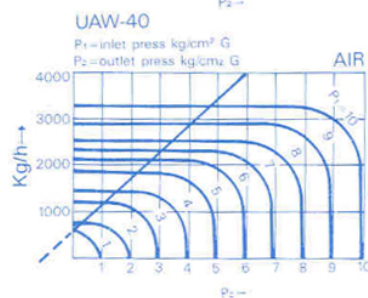
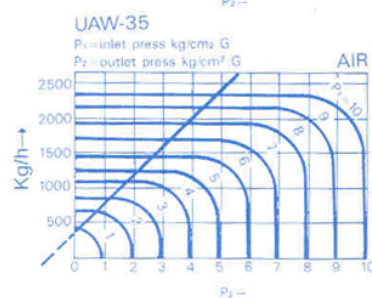
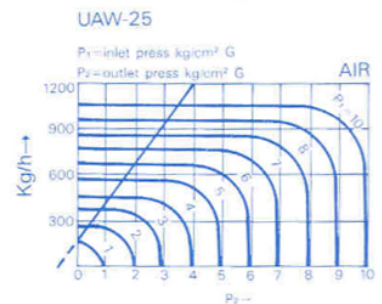
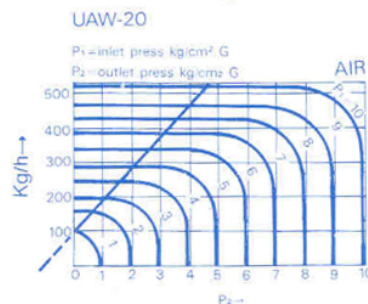
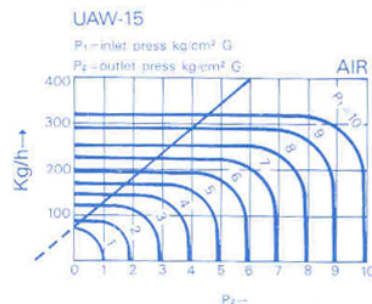
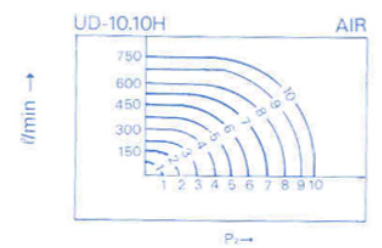
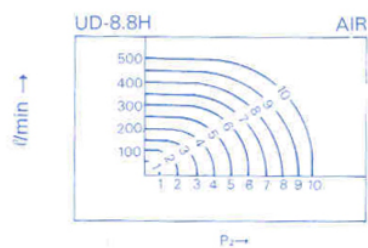
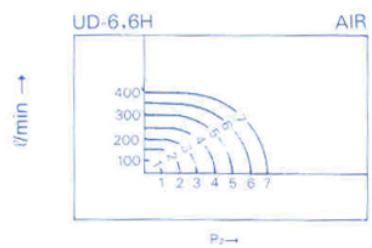
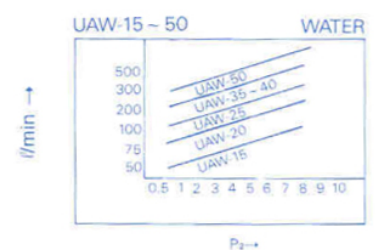
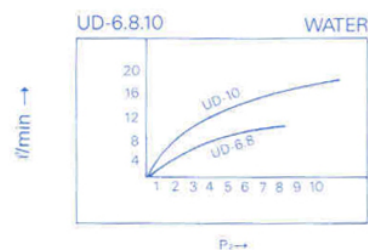
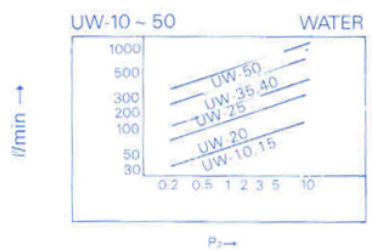
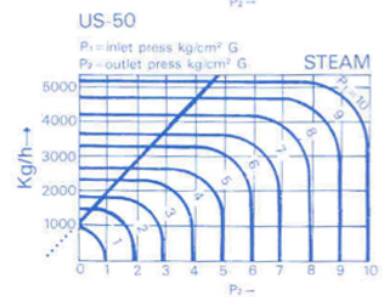
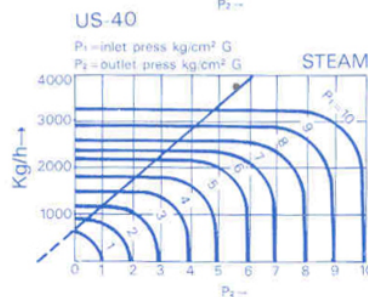
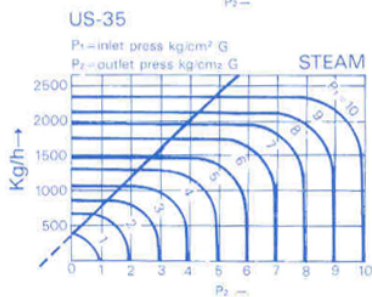
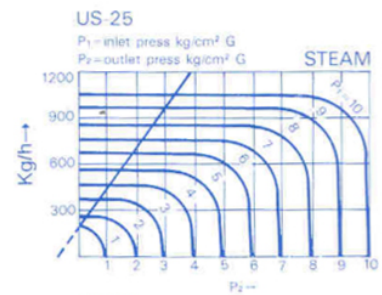
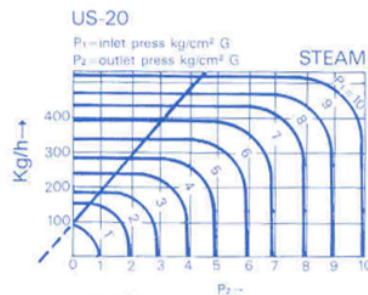
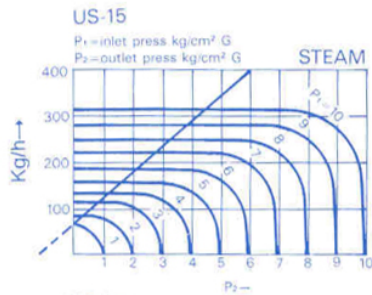

FLOW CHARACTERISTIC CHART

STEAM/AIR P_1 = INLET PRESS KG/CM²
 STEAM/AIR P_2 = OUTLET PRESS KG/CM²
 WATER: DIFF. PRESS KG/CM²

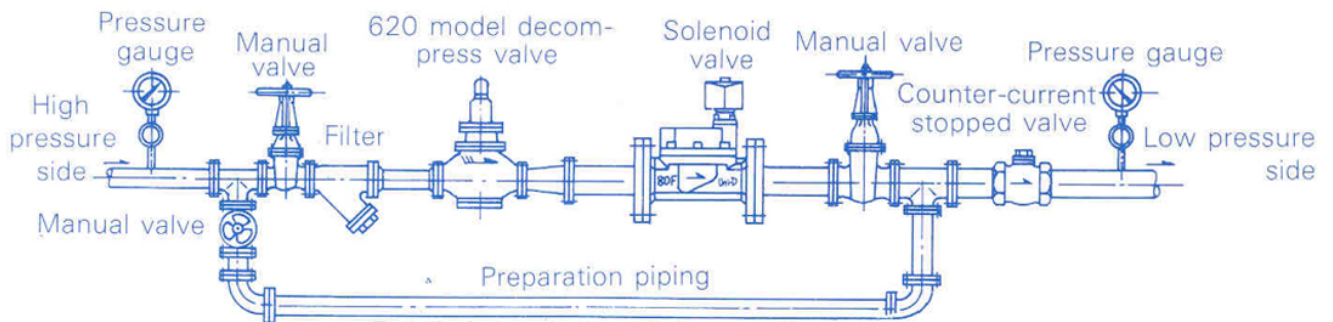
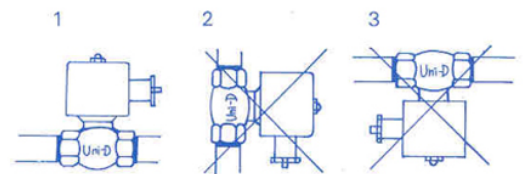
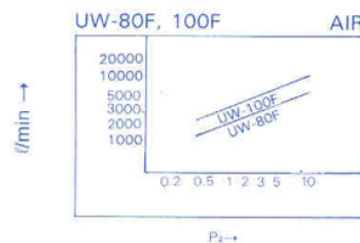
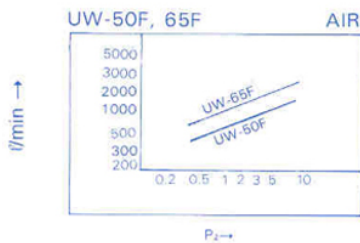
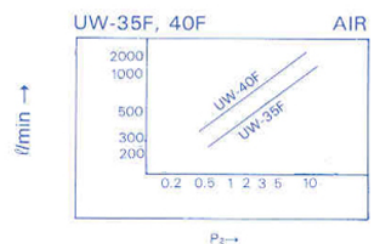
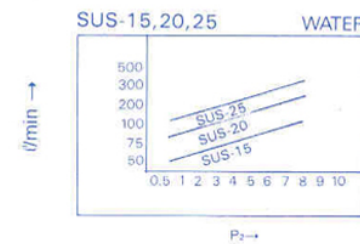
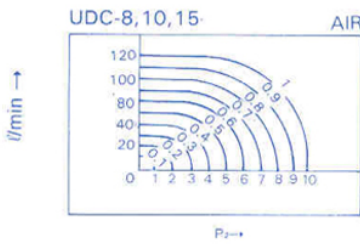
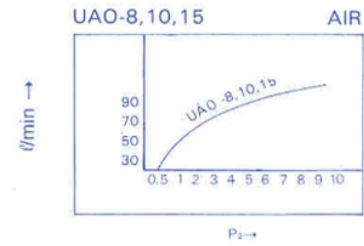
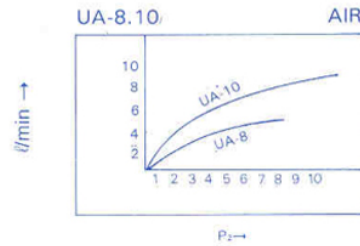
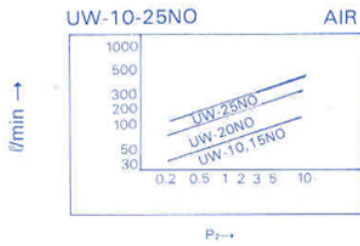
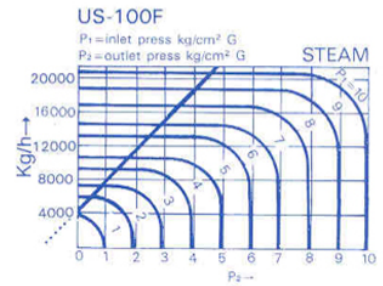
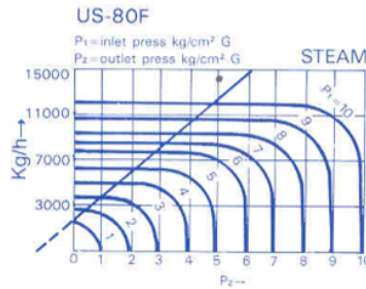
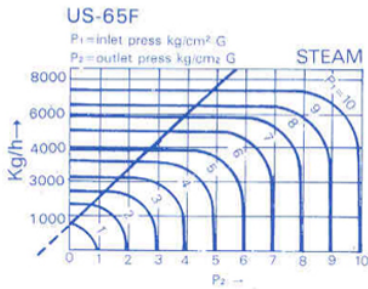
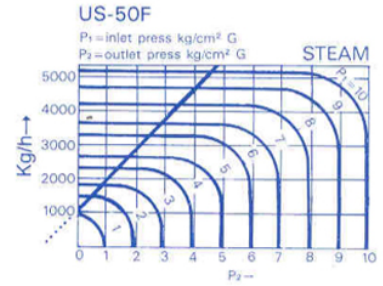
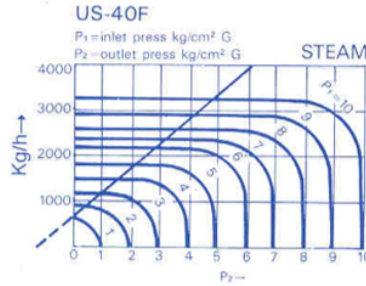
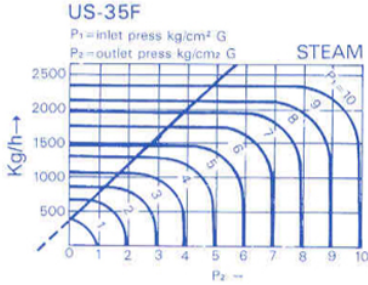

Detailed description of diagram 1

UNI-D[®]

SOLENOID VALVE

UNI-D CORPORATION

AGENT:



CHANGDEL INDUSTRIAL CO., LTD.

P. O. BOX 37-121 TAIPEI, TAIWAN, R. O. C.
3FL., 92-1, SEC. 2, HO PING WEST ROAD,
TAIPEI, TAIWAN, R. O. C.
TELEX: 23463 CHANGDEL
FAX: 886-2-3079818
TEL: (02)3053250, 3053251

CAT. 8000, MAR-91